

SISTEMA DE LAMINACIÓN AXIAL

A-233400x290 / A-233400x290 G / A-233400x290LH / A-233400x290 G LH

Ø Mango (D)	25	30	1"	1 1/4"	1 1/2"	VDI 25	VDI 30	VDI 40
	mm.	mm.						

Dimensiones generales

para roscas derechas

- A-233400x290 solamente para uso fijo.
- A-233400x290 G para uso fijo y rotativo.
- posición inclinación de los rodillos = 1°15'
- peso sin rodillos = aprox. 2,9 Kg.

a= Tirar para abrir

b= Cabezal abre tipo A-233400x290 G, cierra tipo A-233400

c= Cabeza abre tipo A-233400, cierra tipo A-233400x290 G

d= Cabezal de roscar cerrado

e= Cabeza de roscar abierto

α= Ángulo de cierre 30°

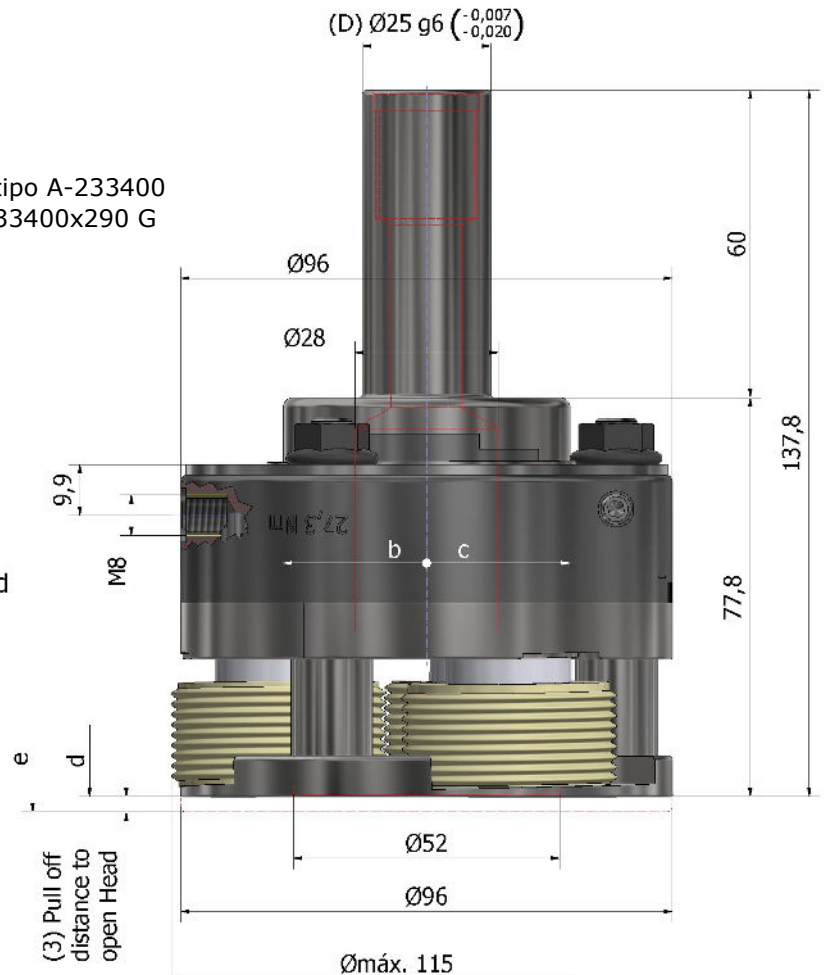
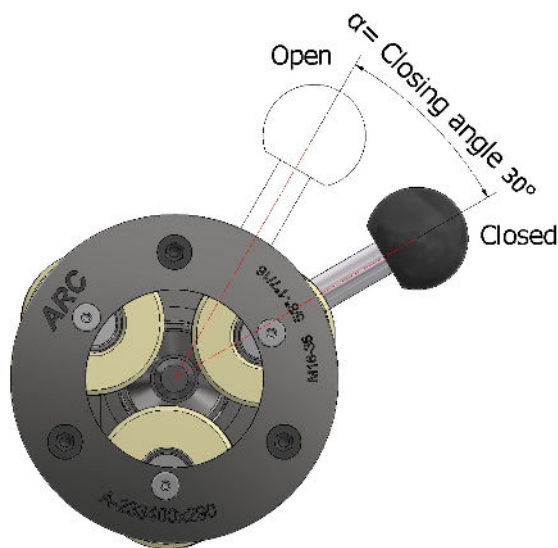

Campos de trabajo

MF	UN / UNF / UNEF	UN / UNF / UNEF	G	BSFS
M 16 ... 18 x 1.5	UNF 5/8 - 18	UNEF 1... 11/16 - 20	G 3/8 - 19	BSFS 5/8... 11/16 - 26
M 18 ... 20 x 1.5	UNEF 5/8 - 24	UNEF 1... 11/16 - 18	G 1/2 - 14	BSFS 5/8... 11/16 - 20
M 20 ... 22 x 1.5	UN 5/8... 11/16 - 20	UN 1... 11/16 - 16	G 5/8 - 14	BSFS 11/16... 3/4 - 26
M 22 ... 24 x 1.5	UNEF 11/16 - 24	UNF 1... 11/16 - 12	G 3/4 - 14	BSFS 11/16... 3/4 - 20
M 24 ... 26 x 1.5	UN 11/16... 3/4 - 20	UN 11/16 ... 11/8 - 20	G 7/8 - 14	BSFS 11/16... 3/4 - 16
M 26 ... 28 x 1.5	UNF 11/16... 3/4 - 16	UNEF 11/16 ... 11/8 - 18	G 1 - 11	BSFS 3/4... 13/16 - 26
M 28 ... 30 x 1.5	UN 3/4 - 24	UNEF 11/16 ... 11/8 - 16		BSFS 3/4... 13/16 - 20
M 30 ... 32 x 1.5	UNEF 3/4... 13/16 - 20	UNF 11/16 ... 11/8 - 12		BSFS 3/4... 13/16 - 16
M 32 ... 34 x 1.5	UN 3/4... 13/16 - 16	UN 11/8 ... 13/16 - 20		BSFS 13/16... 7/8 - 20
M 34 ... 36 x 1.5	UNEF 13/16... 7/8 - 20	UNEF 11/8 ... 13/16 - 18		BSFS 7/8... 15/16 - 20
M 22 ... 24 x 2	UN 13/16... 7/8 - 16	UN 11/8 ... 13/16 - 16		BSFS 15/16... 1 - 20
M 24 ... 26 x 2	UNF 13/16... 7/8 - 14	UN 11/8 ... 13/16 - 12		BSFS 1... 11/16 - 20
M 26 ... 28 x 2	UNF 7/8... 15/16 - 20	UN 13/16 ... 11/4 - 16		BSFS 11/16 ... 11/8 - 20
M 28 ... 30 x 2	UN 7/8... 15/16 - 16	UN 13/16 ... 11/4 - 12		BSFS 11/8 ... 13/16 - 20
M 30 ... 32 x 2	UNF 7/8... 15/16 - 14	UN 11/4 ... 15/16 - 16		BSFS 11/8 ... 13/16 - 12
M 32 ... 34 x 2	UN 7/8... 15/16 - 12	UN 11/4 ... 15/16 - 12		BSFS 13/16 ... 11/4 - 12
M 34 ... 36 x 2	UNEF 15/16... 1 - 20	UN 15/16 ... 13/8 - 16		BSFS 11/4 ... 15/16 - 12
	UN 15/16... 1 - 16	UN 15/16 ... 13/8 - 12		BSFS 15/16 ... 13/8 - 12
	UNF 15/16... 1 - 12	UN 13/8 ... 17/16 - 16		BSFS 13/8 ... 17/16 - 12
		UN 13/8 ... 17/16 - 12		

Repuestos para Cabezales

A-233400x290 / A-233400x290 G / A-233400x290LH / A-233400x290 G

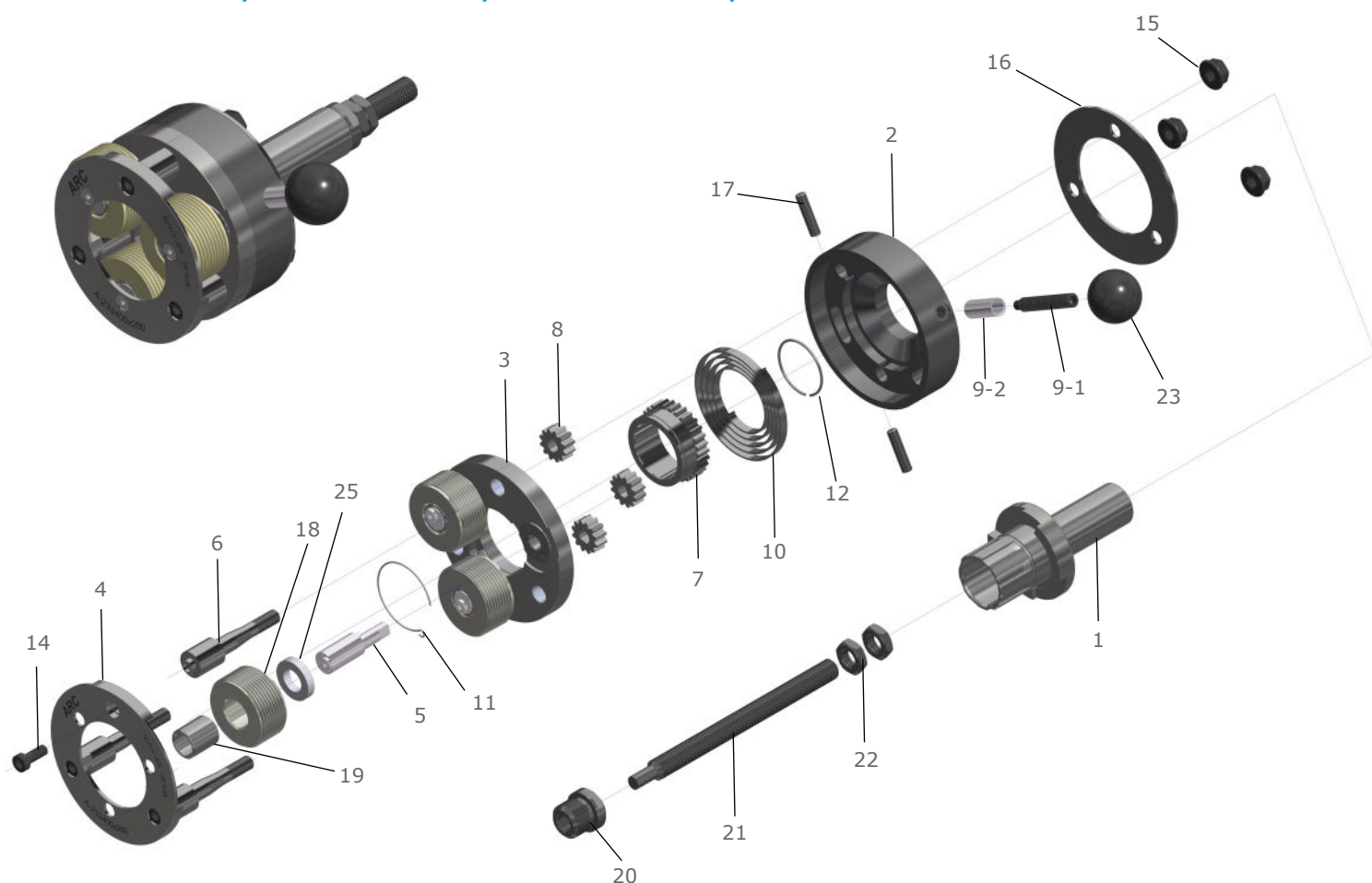

Lista de piezas de repuesto

Nº pieza	Cant.	Descripción
1	1	Mango
2	1	Carter de Resorte
3	1	Placa Trasera
4	1	Placa Delantera
5	3	Excéntrica
6	3	Columna
7	1	Piñón Central
8	3	Piñón Satélite
9-1	1	Espárrago Empuñadura
9-2	1	Casquillo Empuñadura
10	1	Muelle
11	1	Anillo Cabezal

Nº pieza	Cant.	Descripción
12	1	Arillo Cabezal
14	3	Tornillo Fijación
15	3	Tuerca Fijación
16	1	Tapa de Obturación
17	2	Espárrago Cabezal
18	3	Rodillo
19	3	Buje, Metal Duro
20	1	Turca del Tope
21	1	Tornillo del Tope
22	2	Contratuerca del Tope
25	3	Suplemento de Rodillos