

AXIAL ROLLING SYSTEMS

A-233400x290 / A-233400x290 G / A-233400x290LH / A-233400x290 G LH

Ø Shank (D)	25	30	1"	1 1/4"	1 1/2"	VDI	VDI	VDI
	mm.	mm.				25	30	40

General dimensions

for right-hand threads

- A-233400x290 to be used stationary only
- A-233400x290 G for stationary and rotary use
- inclined position of rolls = 1°15'
- weight without rolls = approx. 2.9Kg.

a= Pull off for opening

b= head opens type A-233400x290 G, closes type A-233400x290

c= head opens type A-233400x290 , closes type A-233400x290 G

d= Rolling Head closed

e= Rolling Head opened

α= Closing angle 30°

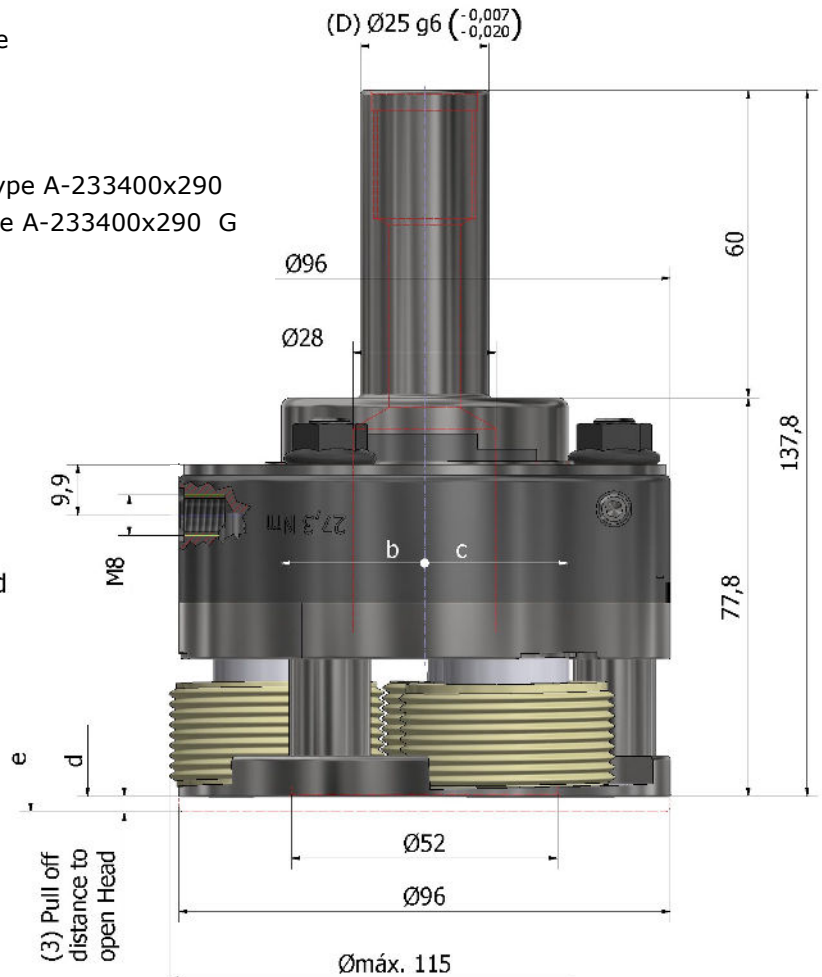
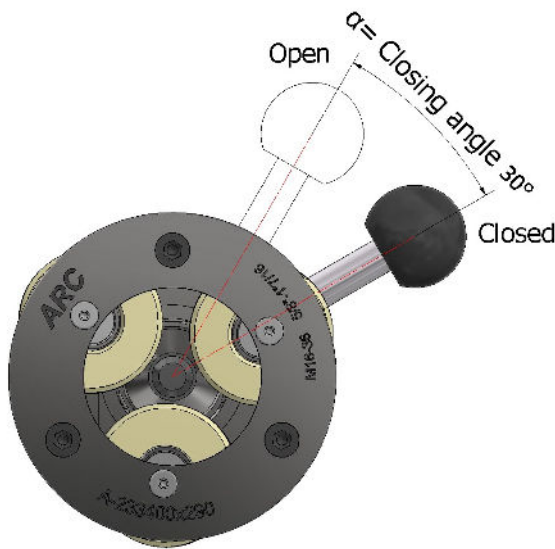

Working range

MF	UN / UNF / UNEF	UN / UNF / UNEF	G	BSFS
M 16 ... 18 x 1.5	UNF 5/8 - 18	UNEF 1... 11/16 - 20	G 3/8 - 19	BSFS 5/8... 11/16 - 26
M 18 ... 20 x 1.5	UNEF 5/8 - 24	UNEF 1... 11/16 - 18	G 1/2 - 14	BSFS 5/8... 11/16 - 20
M 20 ... 22 x 1.5	UN 5/8... 11/16 - 20	UN 1... 11/16 - 16	G 5/8 - 14	BSFS 11/16... 3/4 - 26
M 22 ... 24 x 1.5	UNEF 11/16 - 24	UNF 1... 11/16 - 12	G 3/4 - 14	BSFS 11/16... 3/4 - 20
M 24 ... 26 x 1.5	UN 11/16... 3/4 - 20	UN 11/16 ... 11/8 - 20	G 7/8 - 14	BSFS 11/16... 3/4 - 16
M 26 ... 28 x 1.5	UNF 11/16... 3/4 - 16	UNEF 11/16 ... 11/8 - 18	G 1 - 11	BSFS 3/4... 13/16 - 26
M 28 ... 30 x 1.5	UN 3/4 - 24	UNEF 11/16 ... 11/8 - 16		BSFS 3/4... 13/16 - 20
M 30 ... 32 x 1.5	UNEF 3/4... 13/16 - 20	UNF 11/16 ... 11/8 - 12		BSFS 3/4... 13/16 - 16
M 32 ... 34 x 1.5	UN 3/4... 13/16 - 16	UN 11/8 ... 13/16 - 20		BSFS 13/16... 7/8 - 20
M 22 ... 24 x 2	UNEF 13/16... 7/8 - 20	UNEF 11/8 ... 13/16 - 18		BSFS 7/8... 15/16 - 20
M 24 ... 26 x 2	UN 13/16... 7/8 - 16	UN 11/8 ... 13/16 - 16		BSFS 15/16... 1 - 20
M 26 ... 28 x 2	UNF 13/16... 7/8 - 14	UN 11/8 ... 13/16 - 12		BSFS 1... 11/16 - 20
M 28 ... 30 x 2	UNF 7/8... 15/16 - 20	UN 13/16 ... 11/4 - 16		BSFS 11/16 ... 11/8 - 20
M 30 ... 32 x 2	UN 7/8... 15/16 - 16	UN 13/16 ... 11/4 - 12		BSFS 11/8 ... 13/16 - 20
M 32 ... 34 x 2	UNF 7/8... 15/16 - 14	UN 11/4 ... 15/16 - 16		BSFS 11/8 ... 13/16 - 12
M 34 ... 36 x 2	UN 7/8... 15/16 - 12	UN 11/4 ... 15/16 - 12		BSFS 13/16 ... 11/4 - 12
	UNEF 15/16... 1 - 20	UN 15/16 ... 13/8 - 16		BSFS 11/4 ... 15/16 - 12
	UN 15/16... 1 - 16	UN 15/16 ... 13/8 - 12		BSFS 15/16 ... 13/8 - 12
	UNF 15/16... 1 - 12	UN 13/8 ... 17/16 - 16		BSFS 13/8 ... 17/16 - 12
		UN 13/8 ... 17/16 - 12		

SPARE PARTS FOR ROLLING HEADS

A-233400x290 / A-233400x290 G / A-233400x290LH / A-233400x290 G

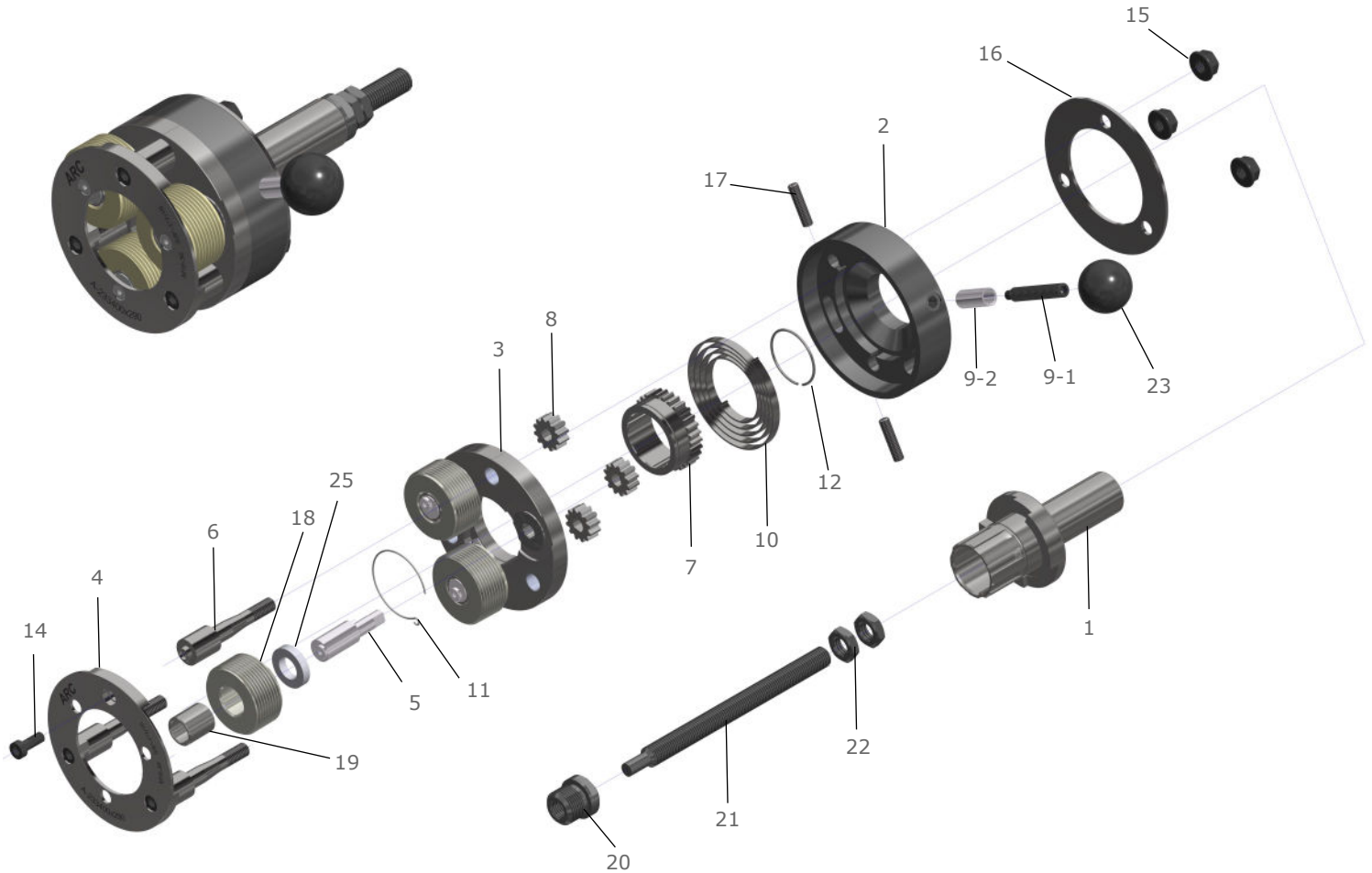

Spare parts list for rolling heads

Part. No	Qty.	Part Description
1	1	Shank
2	1	Spring Housing
3	1	Back Plate
4	1	Front Plate
5	3	Eccentric Spindles
6	3	Spacer Studs
7	1	Center Gear
8	3	Outer Gear
9-1	1	Handle Stud
9-2	1	Handle bushing
10	1	Spring
11	1	Circlip

Part. No	Qty.	Part Description
12	1	Circlip
14	3	Cap Screw
15	3	Hexagon Nut
16	1	Ring Washer
17	2	Head stud
18	3	Thread Roll
19	3	Carbide Bushing
20	1	Stop Sleeve
21	1	Stop Screw
22	2	Stop Screw lock-nut
25	3	Washer